

PERLITE PRODUCT GUIDE

INSULATING UNDERGROUND PIPE AND DUCTING WITH PERLITE INSULATING CONCRETE

Lightweight perlite insulating concrete can play a multiple role in underground pipe and duct installations. In addition to providing quality thermal insulation, perlite concrete insulation can also serve as a supporting envelope. This latter advantage is of special importance when pipe or ducts are laid under roadways, parking lots or other areas subject to traffic. Perlite concrete pipe insulation provides a monolithic (seamless) insulation for the length of a pipe or duct. Additionally, perlite insulating concrete is permanent, fire proof, rot proof and vermin proof.

Stable or Compacted Soils

Where there is stable or compacted soil, pipe or ducting may be supported on precast perlite concrete support blocks in the bottom of a trench and a perlite concrete cover poured into the trench area. Depth of concrete

cover and pipe spacing will depend on the size of pipe or duct to be insulated as well as operating temperatures. The perlite cover should be waterproofed by encasing the perlite concrete with a polyvinyl chloride (PVC) membrane. Internal vent drain lines may be required. If operating temperatures are in excess of 800°F (427°C) Aluminate cement should be employed. Prior to pouring concrete, pipe and ducts should be wrapped with a parting material such as wax coated corrugated paper to prevent the perlite concrete from adhering to the pipe and to permit free longitudinal movement of the pipe as a result of temperature changes.

Disturbed or Loose Soils

When disturbed soils are encountered in the trench area, a perlite concrete base pad should be poured first. Precast perlite concrete support blocks are then placed on top of the base pad and the installation proceeds as for installations in compacted soils.

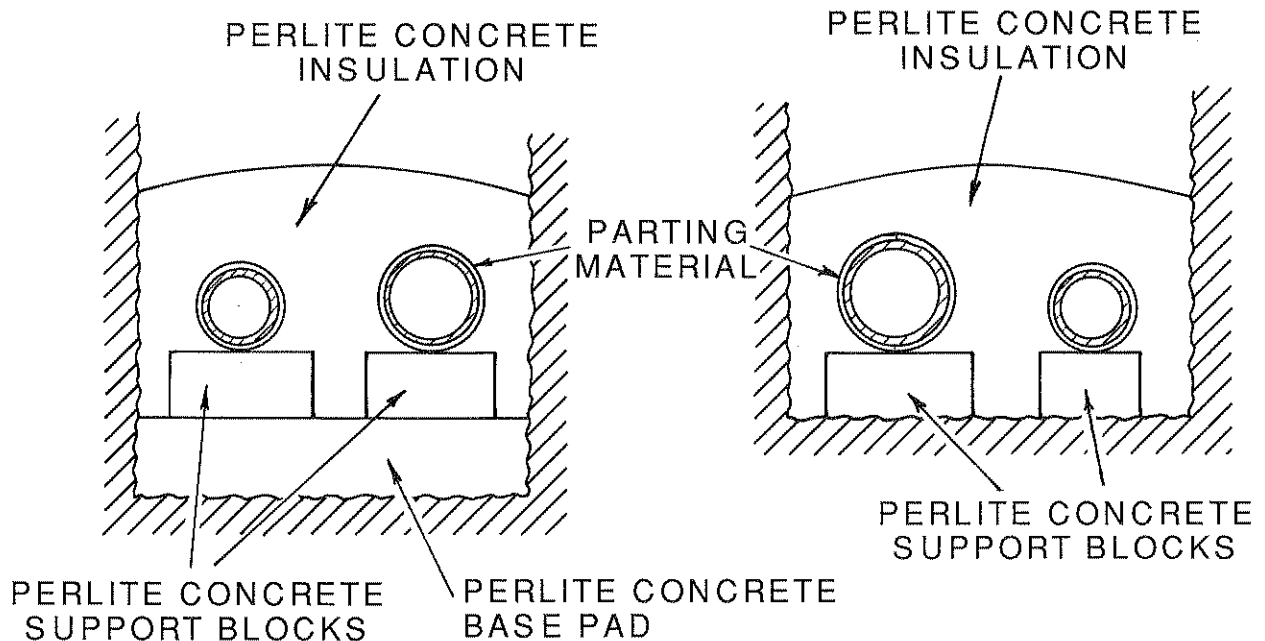

Typical underground pipe installations with perlite concrete insulation. (left) Perlite concrete base pad used when earth has been disturbed. (Right) Base pad eliminated when earth is undisturbed or when it has been compacted. When below grade grade water is present, the installation should be completely encased with a PVC membrane and vent drains installed.

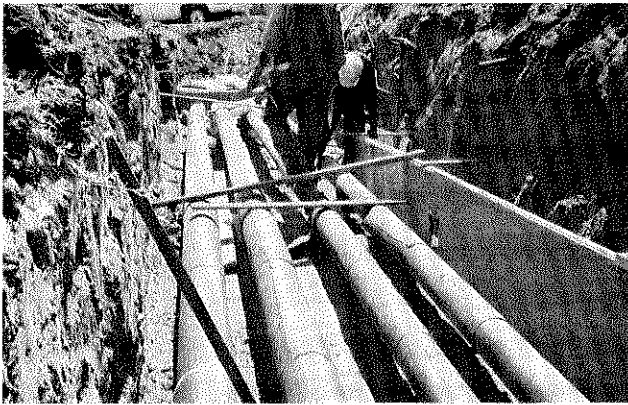

Underground pipe shown wrapped in wax coated corrugated paper prior to pouring of perlite concrete insulation.

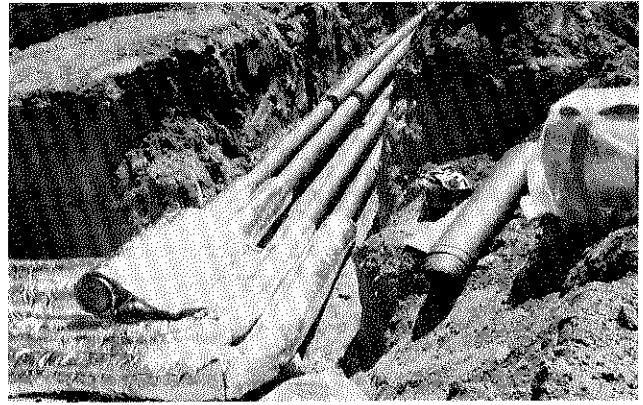

Pipe elbows shown wrapped in double wraps of foil faced fiberglass insulation. Straight lengths of wax coated corrugated cardboard piping are shown at right of photo.

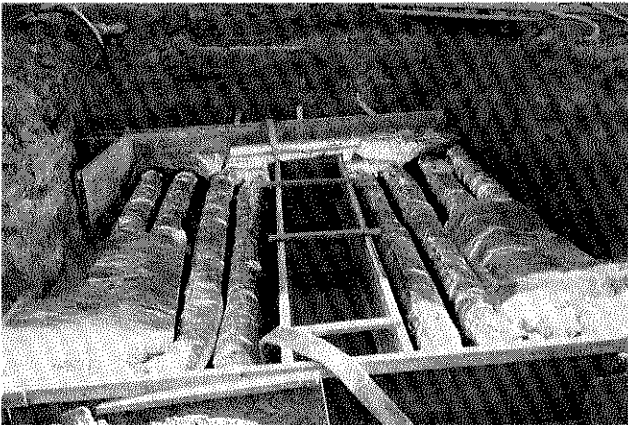

Expansion loop wrapped in double layers of foil faced fiberglass prior to pouring of perlite insulating concrete.

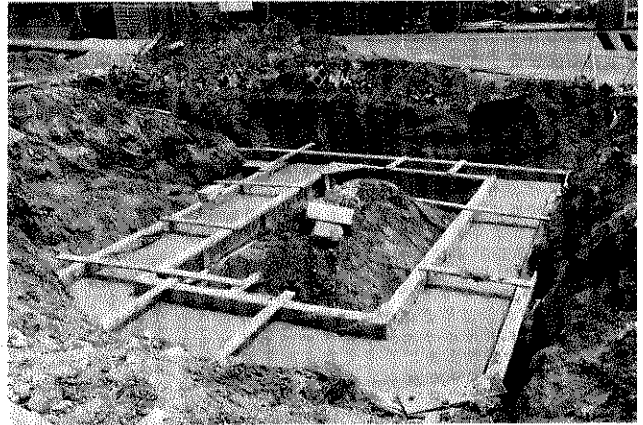

Expansion loop following pouring of perlite insulating concrete prior to overwrapping with PVC membrane.

Expansion Loops or Ells

Expansion loops and ells must be carefully designed as there will be pipe or duct movement in the perlite concrete insulation as a result of temperature changes. Depending on the design, metal pan blockouts can be used to isolate the pipe or ducts from the insulation in those areas where there is excessive movement. Double wraps of 1-1/2 inch (4 cm) foil faced fiberglass may also be used to accommodate pipe movement at elbows, expansion loops, expansion "Z"s and U-bends.

Heavy Traffic Areas

Where there is heavy traffic loading on the soil above

an insulated pipe as when running pipe under parking lots or highways, the designer should take this loading into account.

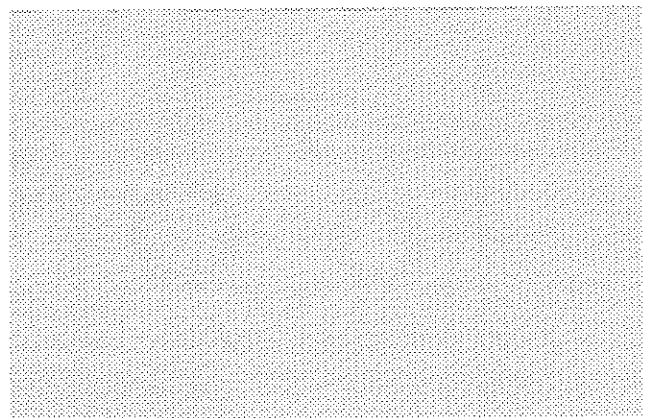

PERLITE INSTITUTE. INC.

**1924 North Second Street, Harrisburg, PA 17102,
717-238-9723, 717-238-9985 (fax), info@perlite.**

Technical data given herein are from sources considered reliable, but no guarantee of accuracy can be made or liability assumed. Your supplier may be able to provide you with more precise data. Certain compositions or processes involving perlite may be the subject of patents.